

REV	DESCRIPTION	DRAWN	DATE

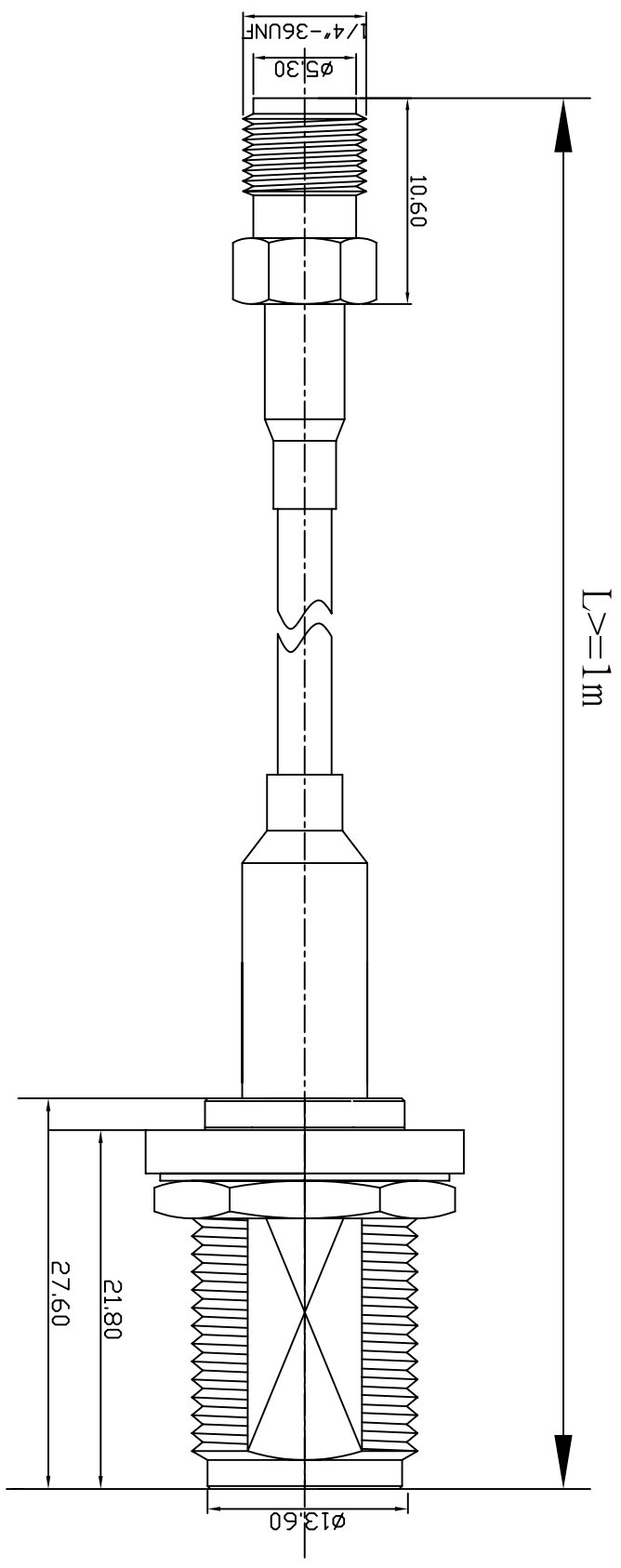

$L \geq 1\text{m}$

NO	Description	Qty	Material	Finish
3	N-1159-1-L-TGN	1	BRASS	NICKEL
2	RG174/RG316/LC100	1		
1	SMA-1011-1-L-TGG	1	BRASS	GOLD

UNLESS OTHERWISE SPECIFIED  
 1.REMOVE ALL BURRS  
 2.BREAK ALL CORNERS & EDGES CO.1.5 MAX.  
 3.CHAMFER 1ST & LAST THREADS 45°.  
 4.DIAMETERS ON COMMON CENTERS TO BE CONCENTRIC WITH DIMENSIONS ARE AFTER PLATING.

\*MAJOR DIMENSION  
 UNLESS OTHERWISE NOTED TOLERANCES  
 0.5-6=±0.2  
 6-30=±0.4  
 30-120=±0.6  
 120-315=±1.0  
 ANGLES=±1°

APPROVED	CHECKED
DRAWN	PEN
DRAWN DATE 04/09/29	

**華耀科技有限公司**  
**Hua Yao Technologies co.,Ltd**  
 TITLE SMA1011-N1159  
 DRAWING NO. 10111/174/316/100/11591-AL  
 REV A  
 FILE NDD\DWG\SMA1011-N1159\10111/174/316/100/11591-AL